

MATERIAL MUST BE ACCORD WITH RoHS STANDARD

版本 REV.	变更内容 DESCRIPTION	变更号 ECN No.	日期 DATA
1.0	ISSUE	REL	2020-01-15
2.0	M2 PCB change 2280 Size	REL	2020-04-11

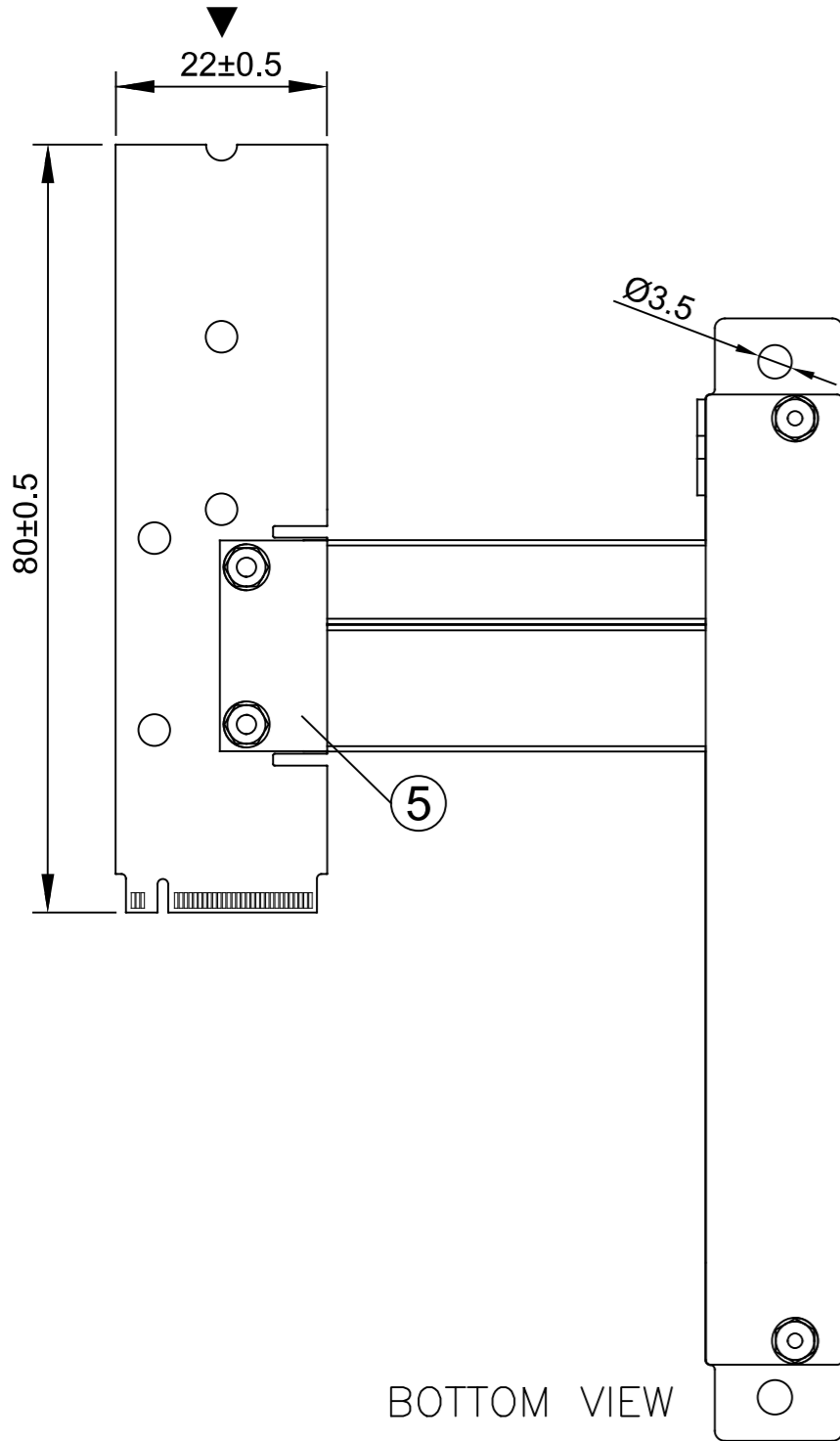

BOTTOM VIEW

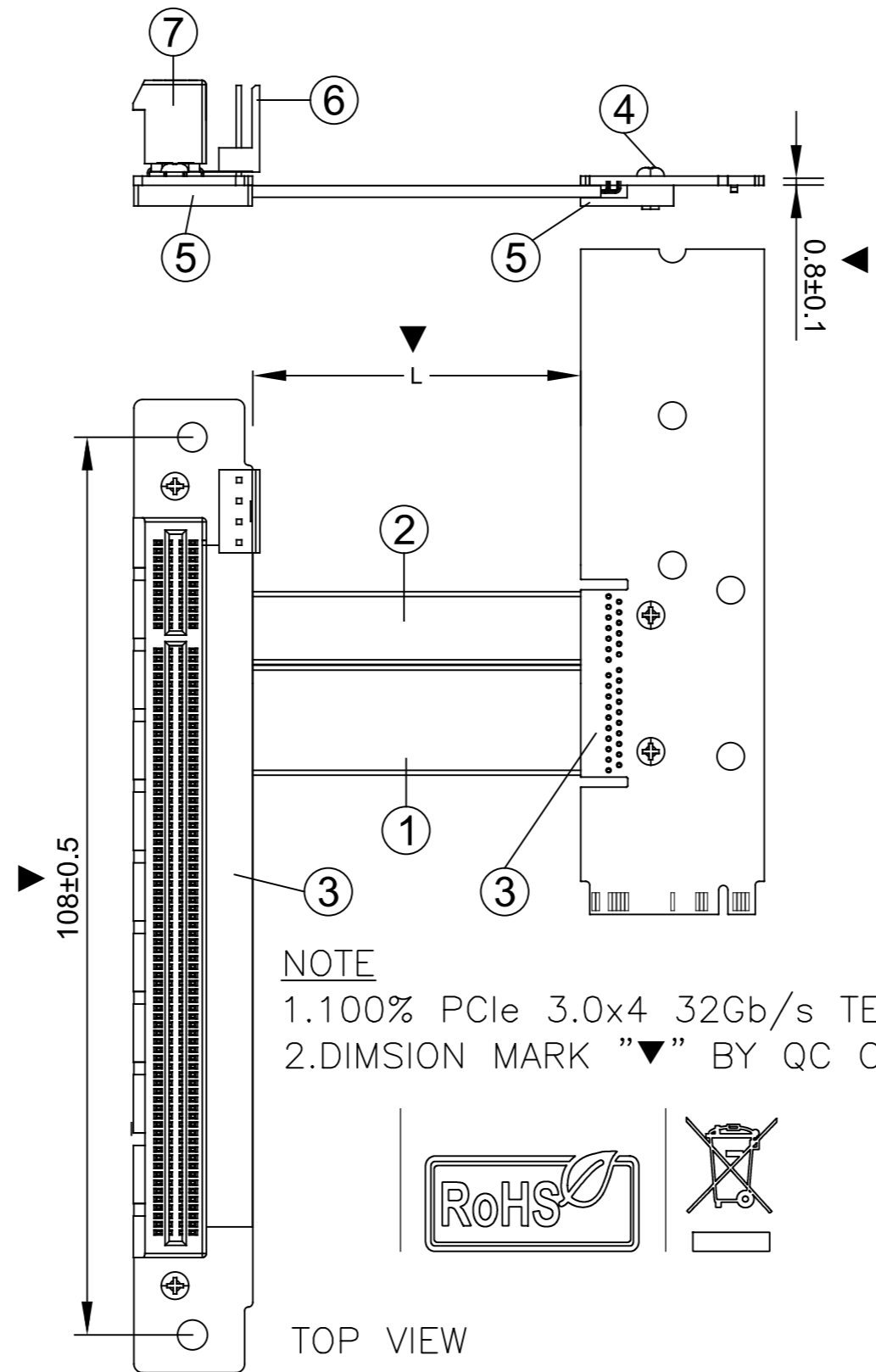

TOP VIEW

NOTE
 1.100% PCIe 3.0x4 32Gb/s TEST.
 2.DIMSION MARK "▼" BY QC CHECK.

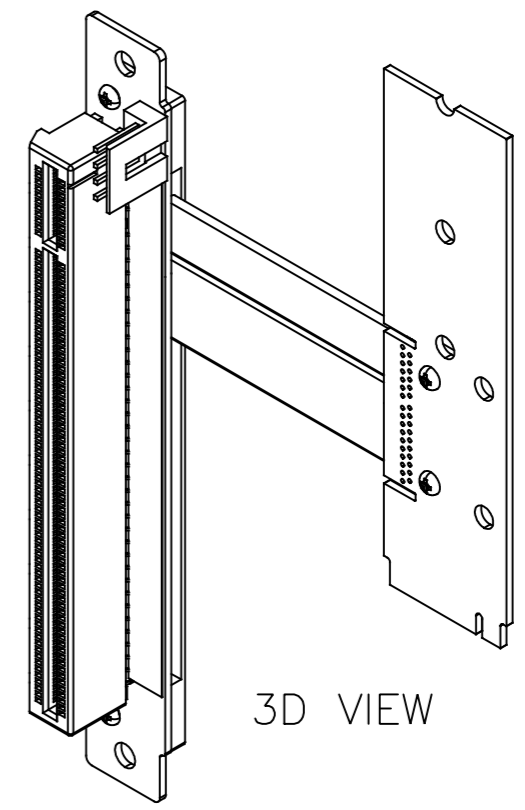
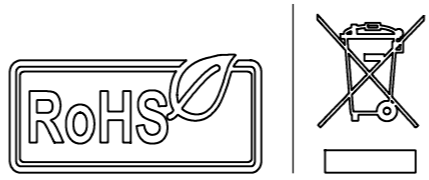

3D VIEW

R43ML-3cm	30±5
R43ML-5cm	50±5
R43ML-10cm	100±5
R43ML-15cm	150±5
R43ML-20cm	200±10
R43ML-25cm	250±10
R43ML-30cm	300±20
R43ML-40cm	400±20
R43ML-50cm	500±20
R43ML-80cm	800±30
Part-Number	Length (mm)

ADT-LINK

No.	PART NO.	DESCRIPTION	Q'TY
7	Connector	PCI-E x16 ,164P Connetor	1Pcs
6	Connector	4P 2.54mm Pitch FLOPPY CONNECTOR	1Pcs
5	PAD	3mm thickness FR4 PCB PAD	2Pcs
4	Screw	M2 screw & hex nut	2Set
3	Tape	Acetate cloth tape	2Pcs
2	CABLE	CABLE,(WIRE13P=30AWG×8P,28AWG×5P),PE ;JACKET:BLACK,OD=1.055×8.85mm (95±15Ω),TPE	1Pcs
1	CABLE	CABLE,(WIRE20P=30AWG×12P,28AWG×8P),PE ;JACKET:BLACK,OD=1.4×13.2mm (95±15Ω),TPE	1Pcs

TITLE: M.2 NVME to PCI-E x16 Extension CABLE L=3~80cm		DWG NO.: ADT-R4M-R3L-002	
		CUSTOMER NO.: ADT	
		CUSTOMER P/N: R43ML-xxxxcm	
	SCALE NONE	UNIT mm	CUS REV. 2.0
			HY REV. 2.0
			DATE 2020-04-11
			SHEET 1/1
DRAWING/制图		CHECKED/审核	
APPROVED/核准			